

Steel beam & channel steel each file per 1500

OH	2700
2	2993
1	3000
floor height	

Shaft Plan
1: 30

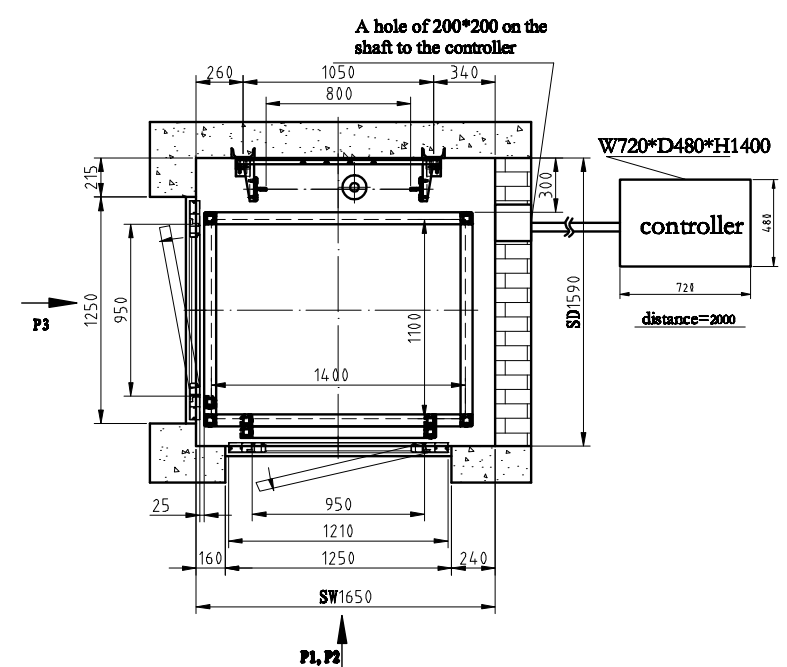

P1, P2

P1, P2 Direction

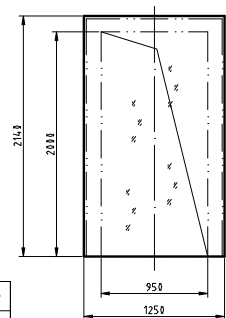

P3 Direction

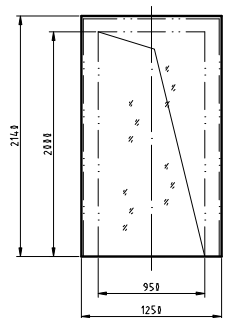

Sketch for landing door assembly
1: 8

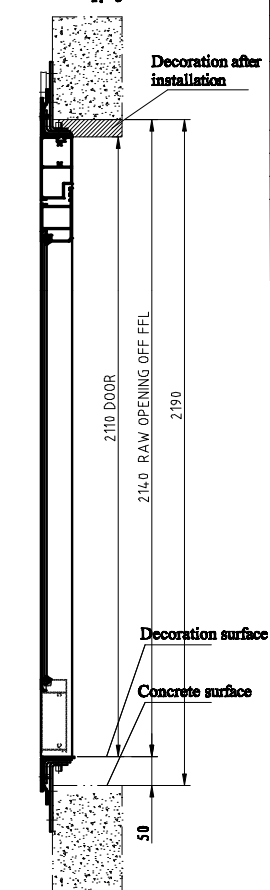

Main Parameters		
Type	TJY320	
Structure	Reinforced concrete	
Load	320kg	
Car Size	1400X1100X2000	
Door	Car door	Without
	Hall door	Swing
	Size	950X2000
Ratio	Side acting 2:1	
Speed	0.25m/s	
Output	2.9KW	
Power Pact	Drive	240V 1 phase
	Light	240V 1 phase
		50Hz 30A

SHOW ROOM:

NSW:
1 / 75 Coriah Circle
Eastgardens NSW 2036
T: (02) 9666 3939
F: (02) 9666 3949

VIC:
1/1 Belghum Ave
Richmond, 3121
T: (03) 9421 4222
F: (03) 9421 4333

QLD:
Home Ideas Centre, 66 Merivale St.
South Bank, Brisbane
T: (07) 3014 0633

WA:
Home Base Expo, 55 Salvado Rd.
Subiaco, Perth
T: (08) 9460 0666

Toll Free: 1800 440 714
www.liftshop.com.au

Drawing No.	D1010020	Controller position	
Project	84823	<input type="checkbox"/> Close	<input type="checkbox"/> Near
Version	3	<input type="checkbox"/> L L R B	<input type="checkbox"/> L L R m
Contract No.	K9807DY4809	320kg hydraulic homelift	
Final Drawing			
Confirmed by customer's signature			
Design	zhushifei	Approve	
Check	zupetga	Date	2010.10.19

