

FLOOR DOOR

Side B	Side C	Side D	VERSION	H LIGHT	H FRAME	FRAME	WINDOW	GLASS	ACCESSORIES
	1 2		Standard RAL 9002 *	2000	2100	RAL 9002 *	Absent		C2

C1 = Enabling key for the floor button pad (single insertion) C2 = Enabling key for the floor button pad (double insertion) PM = Button pad on the wall PE = Outside lock and button pad

(*) Smooth - No raised edges

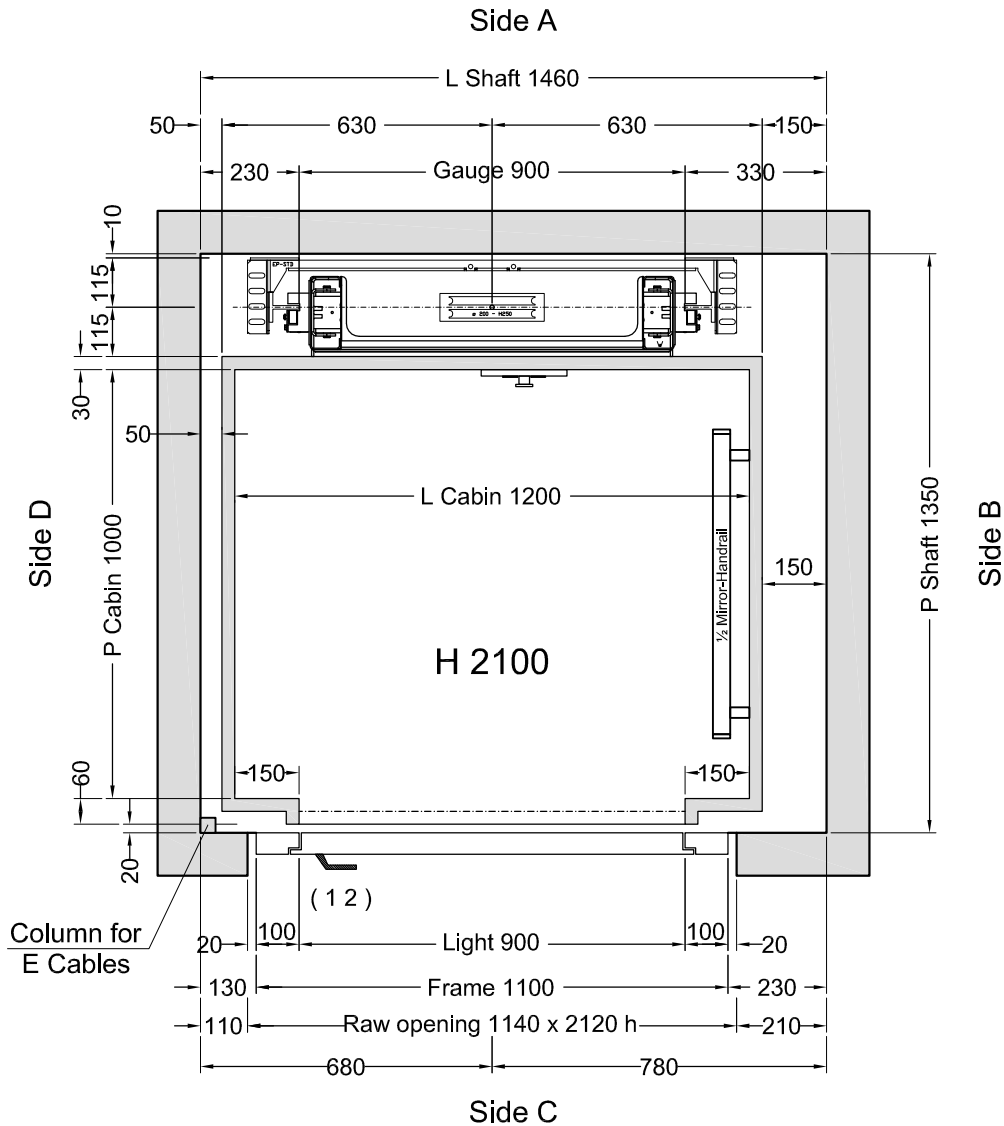

Stops: 2 - Doors: 2

Shaft in **Masonry (Muratura)**

Customer own flooring: Dimensions **1200 (L) x 1030 (P)** thks **20 mm** Weight: **50 kg**

	VERSIONS	Description	Designer	Date	Final Drawings	
ORDER NUMBER					Model	SHEET
PS1470					ELFO	1/2
	Varie modifiche.		L. Del Bianco	31/10/2013		SHEET DIMENS.
			Final Drawings	1° STESURA		A3
CLIENT			L. Del Bianco	06/11/13	SCALE	1:12.5
PLACE OF INSTALLATION			CAPACITY	AREA m ²	CAPACITY	
			300 kg	1,2		

ACCESSORI:

- Chiave abilitazione pulsantiera cabina a doppia estrazione
- Guide in barre da 2,5 m
- Pompa a mano
- Pressostato con segnalazione di sovraccarico
- Due velocità
- Dispositivo falsa testata
- Telefono a cura Lift Shop
- Fotocellula tutta parete
- Manovra Automatica 2011

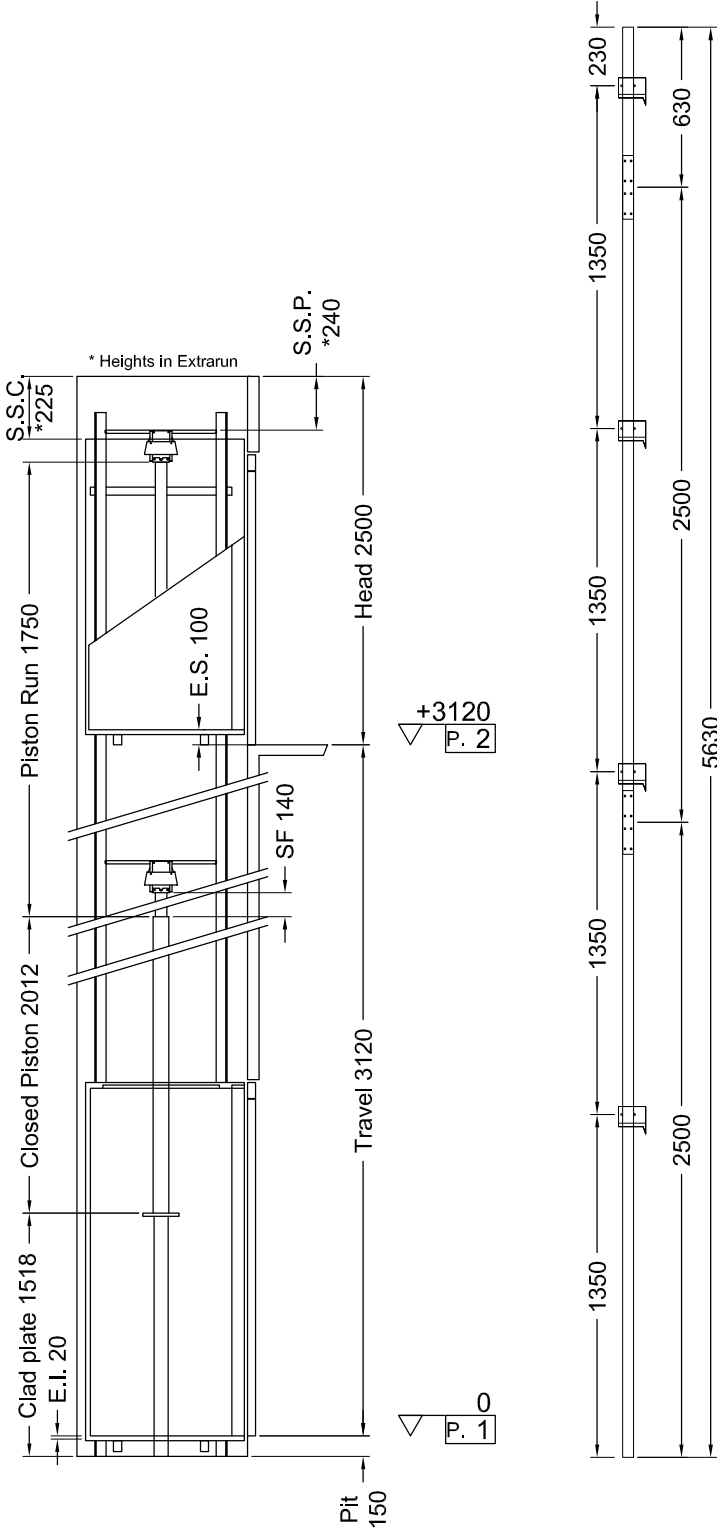

Indirect Installation	Speed 0,3 m/s	06/11/13 11.15 (V.2829)
-----------------------	---------------	-------------------------

THRUST DURING NORMAL OPERATION			THRUST OF SAFETY DEVICE INTERVENT.		
P	(N)	10562	P	(N)	481
N	(N)	512	N	(N)	7072
F1	(N)	1357	F1	(N)	2262
F2	(N)	262	F2	(N)	437

SPACES		PRESSURES		
E.I.	Extrarun below cabin (mm)	20	Max static pressure (bar)	35,5
E.S.	Extrarun above cabin (mm)	100	Min static pressure (bar)	20,2
SF.	Piston extraction (mm)	140	Overpressure limit (bar)	49,69
S.S.P.	Piston/head (mm)	240	Residual pressure (bar)	1,25
S.S.C.	Cabin/head (mm)	225		

HYDRAULIC UNIT		MECHANICAL PARTS	
Central unit	GMV HL 3010 (-*)	Runners	T70-2A
Capacity (l/min)	35	Brackets	(Nr) 4
Motor (V)	MF230V	Cables	Ø 9 mm 6-(1+9+9)
Power (Kw)	2,9	Cables length (mm) 2 x	9000
Corrente (A)	19	Min actual breaking load (N)	47300
Piston	START Homø 70x5x1750		
Opt. oil position	BASSO		
Tubing	3/4" EN 853 1SN - FD 3/4" - GOMITO 3/4"		
Tubing length (mm)	12000		
Min hydraulic oil (L)	41		

SECURITY DEVICES	Manufacturer	Model	Certificate
Safety Gear	LVT	LVT11	TUV DPD 010
Block Valve	START ELEVATOR	1/2" 0327	CA50.00525
Key Locks	TIEFFE	TIEFFE2000	IMQ I0110

MACHINERY LOCATION			
At floor	1	Length of the hose travel	6000 (mm)
Cables enter in shaft: Side	C		

CABIN		CABIN ACCESSORIES	
Panels	Beige Spatolato DT29SMA	½ Mirror	Side B
Finishes	Similinox F12PPS	Handrail	Inox S.B., Side B
Oper. panel	VERTICAL (Like finishes)		
Floor	By Customer		
Roof	LABIRINT - Beige Spatolato DT29SMA		

OTHER ACCESSORIES
Enabling key for the cabin button pad, double insertion
Guides dimension 2.5 m
Manual pump
Manostat with overweight signal
Two speed
False head device
<u>Telephone by Lift Shop</u>
Full height Infra-red curtain
Automatic Control 2011

The information contained in this drawing are completed by masonry manual rev.4 | * See masonry manual rev. 4

	ORDER NUMBER	PS1470	Final Drawings	1° STESURA
			L. Del Bianco	06/11/13
			Final Drawings	
			SCALE	SHEET
			OUT OF SCALE	2/2