

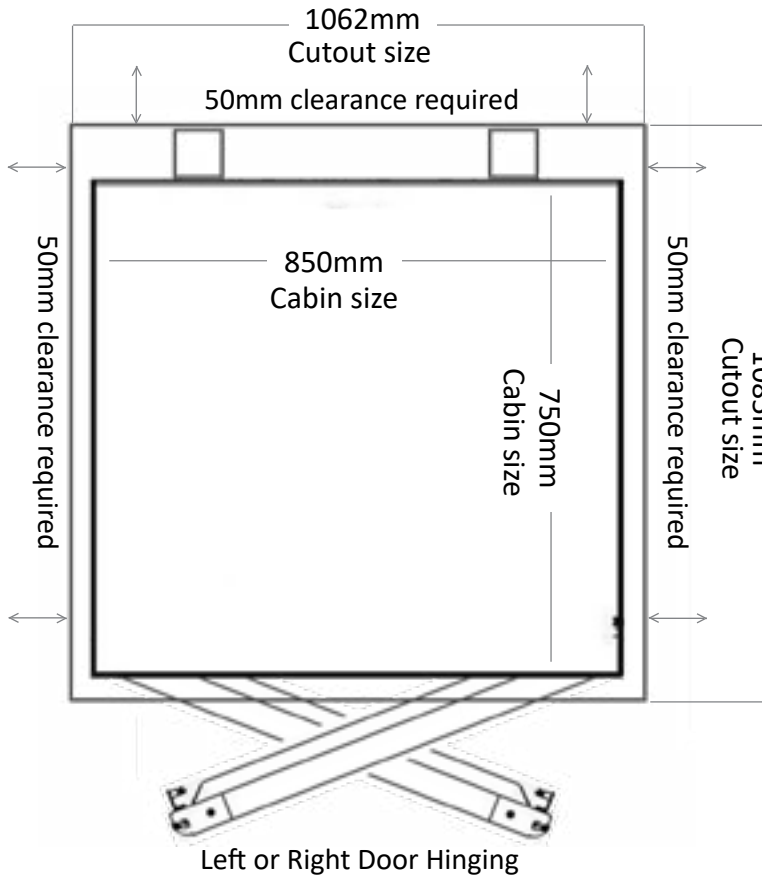

The award winning leader

Q1 • Medium • Custom

Plan View



Sketch

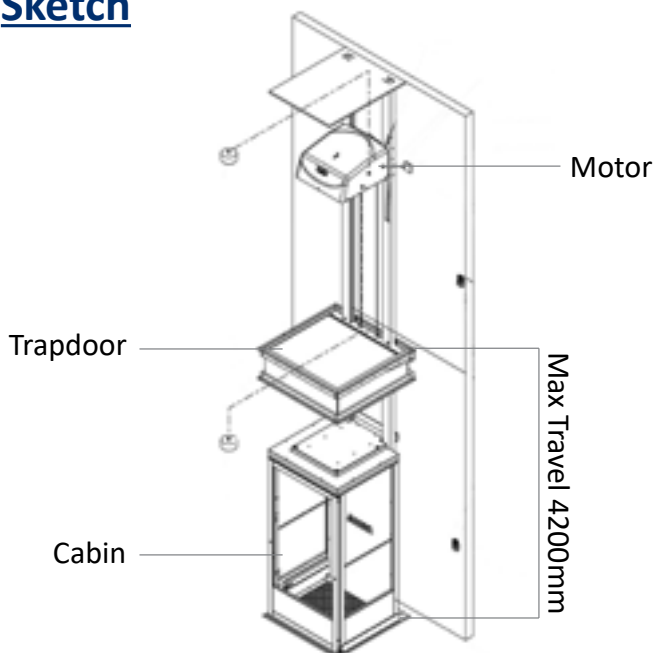

Top Floor Section View

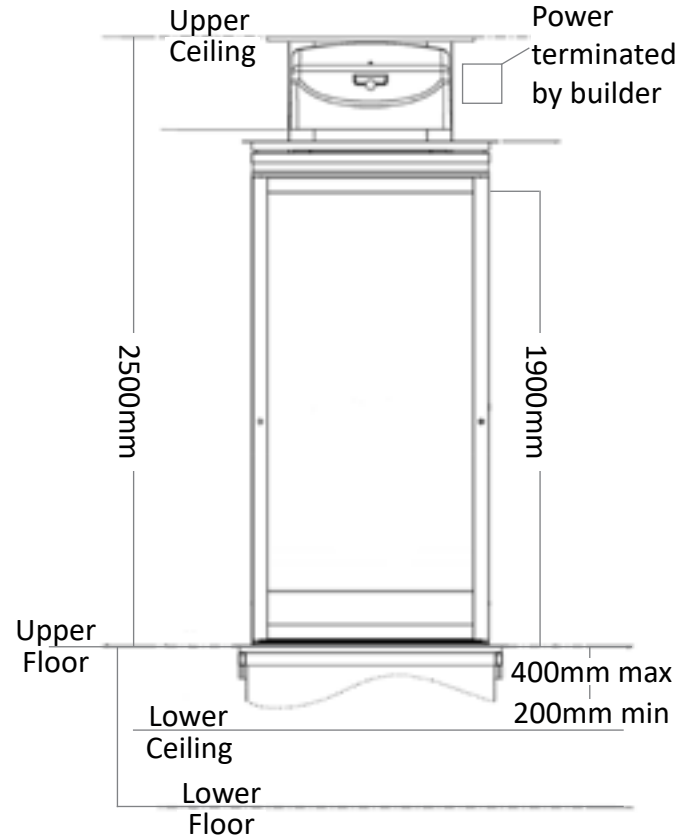

Construction Details

- Pit depth No pit required
- Headroom 2500mm
- Power supply Single phase 230 V 50/60 Hz, 20A
Location to be agreed

Specifications

- Person capacity 3 persons (255kg)
- Cabin height 1900mm
- Door width 850mm
- Speed 0.15m/s
- Maximum travel 4200mm
- Maximum floors 2
- Compliance EN81-41
- Safety Sensors top and bottom of cabin
- Large selection of colours available